

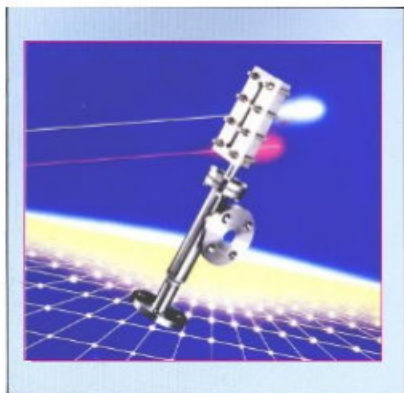

KD型流量計



KD	流量範圍						單位: KG/HR
	STEAM PRESSURE			KG/CM2 G			
SIZE	1K	2K	3K	4K	5K	6K	
15	2-20	2.4-24	3-30	3-32	3.6-36	3.8-38	
20	4-40	4.8-48	6-60	6-64	7-72	7-76	
25	10-100	12-120	14-140	16-160	18-180	19-190	
32	20-200	24-240	28-280	32-320	36-360	38-380	
40	40-400	48-480	56-560	64-640	72-720	76-760	
50	60-600	70-700	80-800	90-900	100-1000	110-1100	
65	100-1000	120-1200	150-1500	160-1600	180-1800	190-1900	
80	130-1300	150-1500	200-2000	210-2100	240-2400	260-2600	
100	160-1600	200-2000	240-2400	260-2600	300-3000	320-3200	
125	200-2000	240-2400	300-3000	320-3200	360-3600	380-3800	
150	300-3000	350-3500	440-4400	470-4700	540-5400	580-5800	

KD外觀尺寸圖

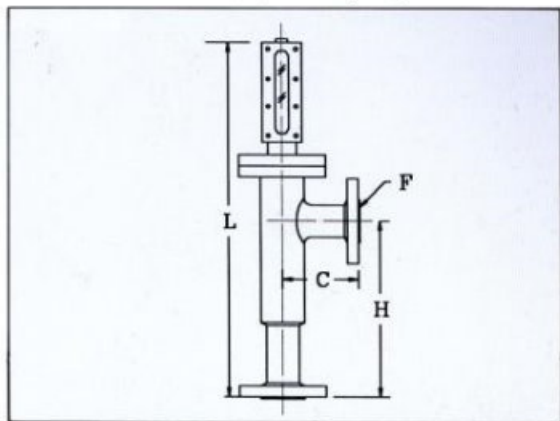

尺寸表:mm適用KAD,KBD,KCD標準型

MODWL	15	20	25	32	40	50	65	80	100	125	150
L	500	510	530	560	560	580	590	680	820	870	900
H	200	200	210	210	210	220	220	300	400	430	450
C	80	80	80	80	100	100	100	120	150	180	200
A	95	100	125	135	140	155	175	185	210	250	270
F	3/8"	3/4	1	1 1/4	1 1/2	2	2 1/2	3	4	5	6

材質表: KD型 (蒸氣用流量計)

	BODY	TAPER TUBE	FLOAT	SEAL			
A	SUS304	A	SUS304	4	SUS304	N	NEOPTENE
B	SUS316	B	SUS316	6	SUS316	V	VITON
C	C.S					A	ASBESTORS
F	OTHER						

- 附註
- 1, 選用流量範圍時,請根據管線壓力為基準。
 - 2, 另訂流量範圍時,請再商談後決定。

型號標示

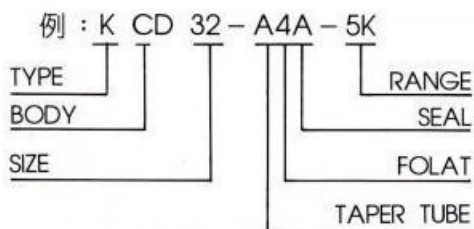

標準型規格: KD

MODEL	KAD, KBD, KCD
MAX TEMP	200°C
MAX PRESS	10 KG/CM2 G
conn	標準型用JIS 10K RF
ACCURACY	±5%

